



TECHNICAL GUIDANCE

For measurement of all kinds of Gas flow

TH Series THERMAL FLOWMETER

GENERAL

TH series THERMAL FLOWMETER is a flowmeter for gas flow measurement. Based on Tokyo Keiso's original theory and measuring principle, the velocity of various kinds of gases are measured by thermal principle. **TH** can cover from very slow velocity to high velocity that offers very wide range ability compared to other methods of velocity detection of Orifice, Vortex etc.

Various types of detectors and converters are available to meet variety of applications and functional requirements.

FEATURES

- High accuracy even in very low flow rate
The thermal flow meter maintains $\pm 1\%$ F.S.*1 of accuracy rating even in such a low flow rate corresponding to 0 to 0.5 m/sec. flow velocity.
- Extremely low pressure loss
The thin cylindrical shape of sensor is effective in minimising line pressure loss.
- Long life
Long term running is guaranteed by the provision of a detector without moving parts and of a converter with a highly reliable circuit.
- Free from line pressure fluctuation
Thanks to basic operational principle, TH Thermal Flowmeter is not affected by a change of a pressure of the gas.
- Negligible influence of gas temperature
In normal usage, gas temperature fluctuation may cause such slight change on output as to be negligible and may be ignored. When gas temperature varies widely during operation and very accurate flow rate is required, temperature compensation function is available.
(Not applicable for TR-1000 converter)
- Mass flow
Mass flow is obtained by measuring gas temperature and computing it by temperature compensation circuit.
- Applicable to various kinds of gases
Based on well analyzed heat conduction mechanism of thin metal tube, applications for gases do not require actual flow rate calibration so long as the physical characteristics are properly specified.
- Cost effectiveness
Even in large pipe size application, the only price increasing factor is thin lead pipes of the detector, So the instrument, as a whole, provides excellent cost effectiveness.
- Wide variation of converter unit
To meet applications and requirements, 4 different types of converter unit are ready to choose.
- High and low temperature version
This version is available for the measurement of gases from -196°C to $+550^{\circ}\text{C}$.
Namely, this flowmeter can be used for the applications with which the conventional one could not comply.

*1 Accuracy of TR-1000 and TRX-5000 converters are $\pm 2.0\%$ F.S.















RECOMMENDED APPLICATION



- Semiconductor Gas supply lines
- Medical Oxygen supply facilities
- Air conditioning
- Utility Gas supply lines in industries
- High Temperature Dry Air lines
- Combustion Gas lines
- Low Pressure and Low Velocity Gas lines
- Incineration Facilities lines
- Electric Power Plant lines
- Flow Rate Measurement System for Automobile Examination lines
- Other Gas supply applications

LINE UP OF TH THERMAL FLOWMETERS

Widely prepared Line-up of **TH** Thermal Flowmeters covers various applications and requirements.

<p>GENERAL PURPOSE SENSORS</p> <p>Air conditioning, general utility, Oxygen line for medical applications.....Different types of sensors are ready.</p>	<div style="display: flex; justify-content: space-around; align-items: flex-start;"> <div style="text-align: center;">  <p>TH-1100 Insertion type</p> </div> <div style="text-align: center;">  <p>TH-1200 Flange type</p> </div> <div style="text-align: center;">  <p>TH-1400 Variable Length Insertion type</p> </div> </div> <div style="display: flex; justify-content: space-around; align-items: flex-start; margin-top: 20px;"> <div style="text-align: center;">  <p>TH-1700 Small sized</p> </div> <div style="text-align: center;">  <p>TH-1800 Built-in Straightener type</p> </div> </div>
<p>SENSOR WITH PURGE FUNCTION</p> <p>Suitable for the lines of incineration plant, and various flow rate measurements under the dust condition.</p>	<div style="display: flex; justify-content: space-around; align-items: center;"> <div style="text-align: center;">  <p>TH-1100-SP Insertion type (Max. Temp. 240°C)</p> </div> <div style="text-align: center;">  <p>TH-3200-SP Insertion type (Max. Temp. 360°C)</p> </div> </div>
<p>HIGH AND LOW TEMP VERSION</p> <p>Special version for measurement of extremely low temperature gases and of very high temperature gases mainly in drying application. Low temp. version covers upto minus 196°C and High temp. version covers upto plus 550°C.</p>	<div style="text-align: center;">  <p>TH-3100, TH-3200, TH-3300 Insertion type</p> </div>
<p>HIGH QUALITY SENSORS</p> <p>For gas supply lines for semi-conduction process, special requirements of nonparticles and low leak rate are asked. HQ series sensors exactly meet this requirement. Gas contact of sensor is EP polished and metal sealing has been adopted for remarkably low He leak rate. Insertion type TH-1100-HQ and In-line welding type TH-1500-HQ are available.</p>	<div style="display: flex; justify-content: space-around; align-items: center;"> <div style="text-align: center;">  <p>TH-1100-HQ Insertion type</p> </div> <div style="text-align: center;">  <p>TH-1500-HQ In-line welding type</p> </div> </div>
<p>CONVERTERS FOR GENERAL PURPOSE SENSORS AND HIGH QUALITY SENSORS</p> <p>General type and Intelligent type, Panel mount type and Field mount type. You can select any one of them which meets your requirement.</p>	<div style="display: flex; justify-content: space-around; align-items: center;"> <div style="text-align: center;">  <p>TRX-600 General, Field mount</p> </div> <div style="text-align: center;">  <p>TRX-700 Intelligent, Panel mount</p> </div> </div> <div style="text-align: center; margin-top: 20px;">  <p>TRX-900 Intelligent, Field mount</p> </div>

COMBINATION EXAMPLES

Converter model	Function							Accuracy (% F.S.)
	Flow rate indication	Total indication	Analog output	Scaled pulse output	Digital output	Flow alarm	Temp. compensation function	
 TRX-600	○	○	○	○	○ (RS-485)	△	△	± 2.0%
 TRX-700	○	○	○	○	○ (RS-485)	○	○	± 1.0%
 TRX-900	○	○	○	○	○ (RS-485)	○	○	± 1.0%

○ : Standard △ : Optionally available × : Not available

TH-3100
TH-3200
TH-3300



TH-1100-SP



TH-3200-SP



TH-1100



TH-1200



TH-1400



TH-1700



TH-1800



TH-1100-HQ



TH-1500-HQ



OPERATION PRINCIPLE

When a heated metallic tubule is located in a gas flow path, the heat of the tubule is removed by the velocity. The lost heat is described by the following formula:

$$H = f(\rho U \times T)$$

Where **H** : Lost heat ρ : Density
U : Velocity **T** : Difference of temperature gas and heated tubule

On the contrary, the generated heat on the tubule is described by the function of supplied voltage and current onto the tubule,

$$W = f(V \times I)$$

Where **W** : Generated heat
V : Supplied voltage **I** : Supplied current

When the heated tubule is in balanced condition, the lost heat and generated heat are equal, and if the **T** is controlled electrically, the velocity is calculated from the figures of supplied voltage and current

$$\rho U = f(V \times I)$$

The total flow rate is calculated from the velocity and the cross section area of flow path:

$$Q = \rho U \times A$$

Where **Q** : Flow rate **U** : Average velocity
A : Cross section area of flow path

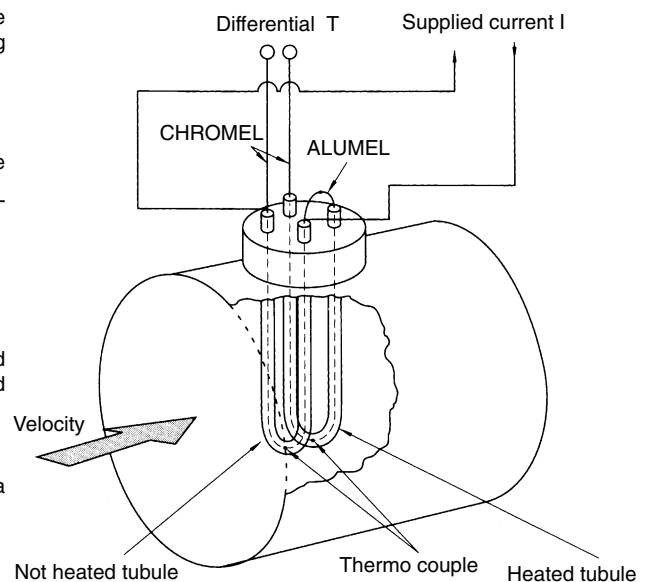

FOR GENERAL PURPOSE

TH-1100

OUTLINE

TH-1100 is an insertion type detector of light weight and small size for easy installation.

Low cost measurement possible even for large size line. Besides normal pipe line, gas flow measurement in square duct also possible.

MODEL CODE

TH—11	Model code					Description
	①	②	③	④	⑤	
① Process pipe size	5					50 mm (2")
	6					65 mm (2-1/2")
	7					80 mm (3")
	8					100 mm (4")
	9					125 mm (5")
	A					150 mm (6")
	B					200 mm (8")
	C					250 mm (10")
	D					300 mm (12")
	E					350 mm (14")
F					Others	
② Sensor material	1					SUS304
	2					SUS316
	3					SUS316L
	F					Special
③ Process connection	1					32A JIS10K flange
	2					1-1/4" ANSI 150 flange
	F					Others
④ L length	1					Standard
	F					Special
⑤ Special						Standard type (Blank)
			W			Terminal box type (Make it blank if in case of connector type.)
			E			EP grade: Electrolytic polishing (Except sensor part)
			B			BA grade: Electrolytic polishing (Except sensor part)

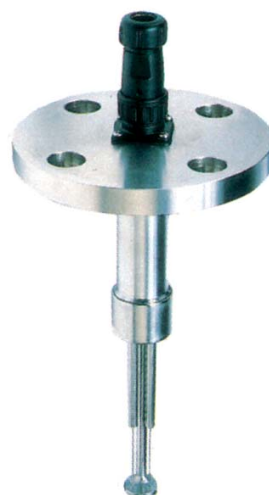

DIMENSION

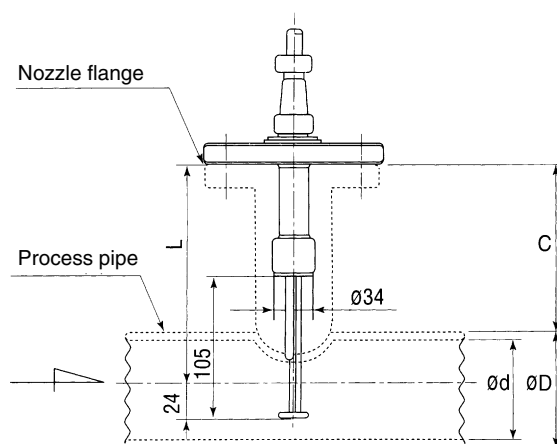

STANDARD SPECIFICATION

Type	Insertion type (Std. 32 mm JIS10K flange)	
Available size	50 mm (2") to 1500 mm (60") * Up to 1500 mm size available on request.	
Measuring range	Min.	Air : 0 to 0.5 m/s (nor)
	Max.	Air : 0 to 130 m/s (nor)
Max. Op. Press	1.0 MPa	
Max. Op. Temp. segment	80°C / 180°C / 240°C	
Material	Sensor	SUS316
	Detector	SUS304, SUS316, SUS316L
	Seal	FPM, Others Construction
Water proof	IP65 equiv.	
Required upstream straight run (Recommendation)	20D (D: Inside diameter)	

Process pipe size (mm)	L (mm)
50 to 150	182
200 to 250	200
300 to 350	250
More than 400	Consult factory for details

Note:

- In case of the dimension except our standard one, advise us of therequired dimension for "L" or "C".
- Advise us of the dimension for "Ød" and "ØD".

TH-1200

OUTLINE

TH-1200 is a flange connected detector.
Perfect fit on process piping.
6 sizes from 50 mm to 150 mm available.



MODEL CODE

TH-12	Model code				Description
	①	②	③	④	
① Process pipe size	5				50 mm (2")
	6				65 mm (2-1/2")
	7				80 mm (3")
	8				100 mm (4")
	9				125 mm (5")
	A				150 mm (6")
② Sensor material	1				SUS304
	2				SUS316
	3				SUS316L
	F				Special
③ Process connection			3		JIS10K flange
			4		ANSI 150 flange
			F		Others
⑤ Special					Standard type (Blank)
			W		Terminal box type (Make it blank if in case of connector type.)
			S		With straightener built in
			E		EP grade: Electrolytic polishing (Except sensor part)
			B		BA grade: Electrolytic polishing (Except sensor part)
			T		With tap for thermometer installation (Rc1/8)

STANDARD SPECIFICATION

Type	Flange ended	
Available size	50 mm (2") to 150 mm (6")	
Measuring range	Min.	Air : 0 to 0.5 m/s (nor)
	Max.	Air : 0 to 130 m/s (nor) (Without straightener) Air : 0 to 40 m/s (nor) (With straightener)
Max. Op. Press.	1.0 MPa	
Max. Op. Temp. segment	80°C / 180°C	
Material	Sensor	SUS316
	Detector	SUS304, SUS316, SUS316L
	Seal	FPM, Others Construction
Water proof	IP65 equiv.	
Required upstream straight run (Recommendation)	20D (Without straightener) (D: Inside diameter)	
	3D to 5D (With straightener)	

DIMENSION

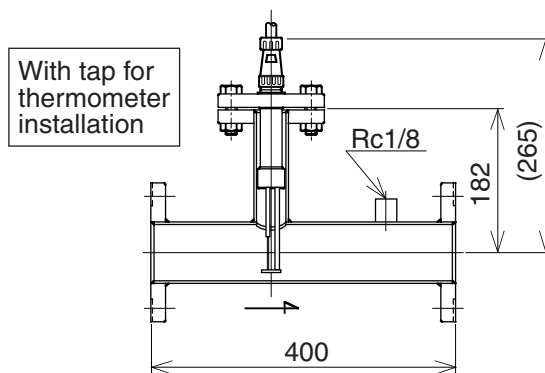
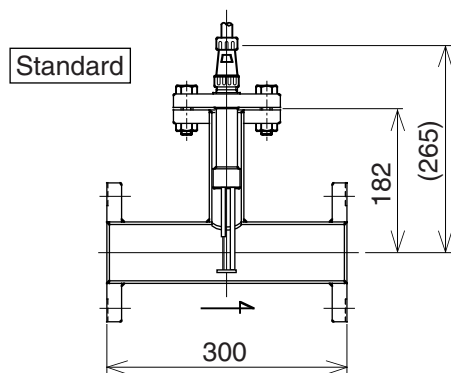

Straightener

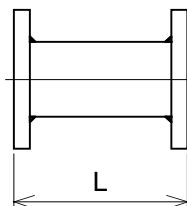

Process pipe size	50 mm	65 mm	80 mm	100 mm	125 mm	150 mm
L	80	90	100	130	150	190

TH THERMAL FLOWMETER

TH-1400

OUTLINE

TH-1400 is a variable length insertion detector provided for checking flow profile in pipe line. Gate valve (customer's supply) can be added for easy maintenance without interrupting process operation.

MODEL CODE

TH—14	Model code					Description
	①	②	③	④	⑤	
① Process pipe size	5					50 mm (2")
	6					65 mm (2-1/2")
	7					80 mm (3")
	8					100 mm (4")
	9					125 mm (5")
	A					150 mm (6")
	B					200 mm (8")
	C					250 mm (10")
	D					300 mm (12")
	E					350 mm (14")
F					Others	
② Sensor material	1					SUS304
	2					SUS316
	3					SUS316L
	F					Special
③ Process connection	1					40A JIS10K flange
	2					1-1/2" ANSI 150 flange
	F					Others
④ L length	1					Standard
	F					Special
⑤ Special						Standard type (Blank)
				W		Terminal box type (Make it blank if in case of connector type.)
				E		EP grade: Electrolytic polishing (Except sensor part)
				B		BA grade: Electrolytic polishing (Except sensor part)



DIMENSION

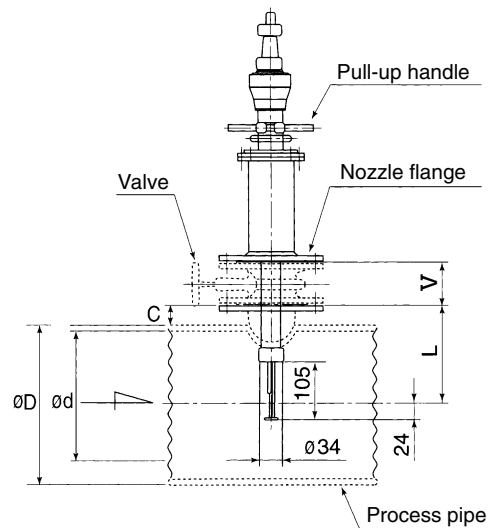

STANDARD SPECIFICATION

Type	Insertion type (Std. 40 A JIS10K flange)	
Available size	50 mm (2") to 1500 mm (60") * Up to 1500 mm size available on request.	
Measuring range	Min.	Air : 0 to 0.5 m/s (nor)
	Max.	Air : 0 to 130 m/s (nor)
Max. Op. Press.	1.0 MPa	
Max. Op. Temp. segment	80°C / 180°C	
Material	Sensor	SUS316
	Detector	SUS304, SUS316, SUS316L
	Seal	FPM, PTFE Others
Water proof	IP65 equiv.	
Required upstream straight run (Recommendation)	20D (D: Inside diameter)	

Process pipe size (mm)	L (mm)
50 to 150	182
200 to 250	200
300 to 350	250
More than 400	Consult factory for details

Note:

- In case of the dimension except our standard one, advise us of the required dimension for "L" or "C".
- Advise us of the dimension "V" for valve if it is used.

TH-1700

OUTLINE

TH-1700 series can be manufactured from the nominal diameter 15 mm to 50 mm.

The process connection is only flange connection type.
5 sizes from 15 mm to 50 mm available.



MODEL CODE

TH-17	Model code					Description
	①	②	③	④	⑤	
① Process pipe size	1					15 mm (1/2")
	2					20 mm (3/4")
	3					25 mm (1")
	4					40 mm (1 1/2")
	5					50 mm (2")
② Operating Temp. range	1					Std. / Temp. range (0 to 80°C)
	2					High Temp. / Temp. range (0 to 180°C)
	7					Low Temp. / Protected against dew condensation (-20 to + 80°C)
③ Sensor material		4				SUS304 / SCS14
		5				SUS316 / SCS14
		6				SUS316L / SCS16
④ Process connection		1				JIS10K flange
		F				Others
⑤ Special						Standard type (Blank)
			E			EP grade: Electrolytic polishing (Except sensor part)
			B			BA grade: Electrolytic polishing (Except sensor part)
			T			With tap for thermometer installation (Rc1/8)
			C			Connector type (For built-in type)

STANDARD SPECIFICATION

Type	Flange ended	
Available size	15 mm (1/2") to 50 mm (2")	
Measuring range	Min.	Air : 0 to 0.5 m/s (nor)
	Max.	Air : 0 to 130 m/s (nor)
Max. Op. Press.	1.0 MPa	
Max. Op. Temp. segment	80°C / 180°C	
Material	Sensor	SUS316
	Detector	SCS14, SCS16, SUS304, SUS316, SUS316L
	Seal	FPM, Others Construction
Water proof	IP65 equiv.	
Required upstream straight run (Recommendation)	20D (D: Inside diameter)	

DIMENSION

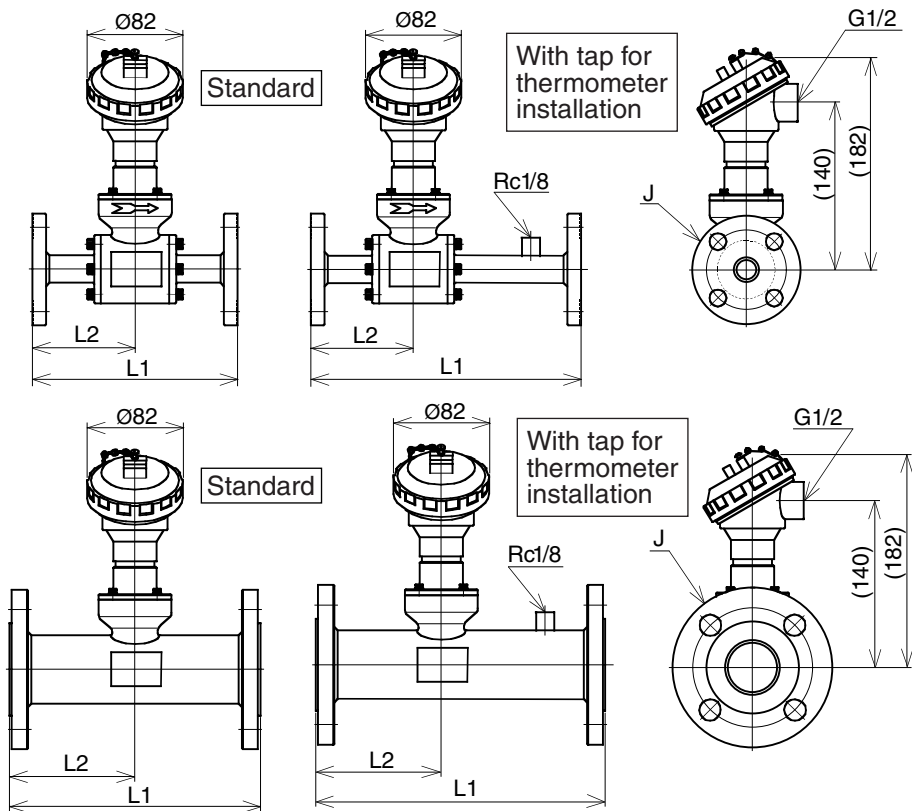

Standard type

Size	L1	L2	J
15 mm	180	90	15A JIS10K flange
20 mm			20A JIS10K flange
25 mm			25A JIS10K flange
40 mm	300	150	40A JIS10K flange
50 mm			50A JIS10K flange

With tap for thermometer installation type

Size	L1	L2	J
15 mm	270	90	15A JIS10K flange
20 mm			20A JIS10K flange
25 mm			25A JIS10K flange
40 mm	330	150	40A JIS10K flange
50 mm			50A JIS10K flange

TH THERMAL FLOWMETER

TH-1800

OUTLINE

TH-1800 has a built-in flow straightener which eliminates the necessity of straight run upstream and downstream.

(Slight pressure loss is created by this built-in flow straightener. Consult factory when process pressure is very low.)

MODEL CODE

TH—18	Model code					Description
	①	②	③	④	⑤	
① Process pipe size	1	-	-	-	-	15 mm (1/2")
	2	-	-	-	-	20 mm (3/4")
	3	-	-	-	-	25 mm (1")
	4	-	-	-	-	40 mm (1 1/2")
	5	-	-	-	-	50 mm (2")
② Operating Temp. range	1	-	-	-	-	Std. / Temp. range (0 to 80°C)
	2	-	-	-	-	Temp. range (0 to 180°C)
	7	-	-	-	-	Low Temp. / Protected against dew condensation (-20 to + 80°C)
③ Sensor material	4	-	-	-	-	SUS304 / SCS14
	5	-	-	-	-	SUS316 / SCS14
	6	-	-	-	-	SUS316L / SCS16
④ Process connection	1	-	-	-	-	JIS10K flange
	2	-	-	-	-	JIS Rc screw (3/8")
	3	-	-	-	-	JIS Rc screw (1/2")
	4	-	-	-	-	JIS Rc screw (3/4")
	5	-	-	-	-	JIS Rc screw (1")
	F	-	-	-	-	Others
⑤ Special		-	-	-	-	Standard type (Blank)
	E	-	-	-	-	EP grade: Electrolytic polishing (Except sensor part)
	B	-	-	-	-	BA grade: Electrolytic polishing (Except sensor part)
	T	-	-	-	-	With tap for thermometer installation (Rc1/8)
	C	-	-	-	-	Connector type (For built-in type)



STANDARD SPECIFICATION

Type	Flange or Screw ended	
Available size	15 mm (1/2") to 50 mm (2")	
Measuring range	Min.	Air : 0 to 0.5 m/s (nor)
	Max.	Air : 0 to 45 m/s (nor)
Max. Op. Press.	1.0 MPa	
Max. Op. Temp. segment	80°C / 180°C	
Material	Sensor	SUS316
	Detector	SCS14, SCS16, SUS304, SUS316, SUS316L
	Seal	FPM, Others Construction
Water proof	IP65 equiv.	
Required upstream straight run (Recommendation)	3D to 5D (D: Inside diameter)	

*Available process connection and sizes

Nominal diameter Connection	15 mm	20 mm	25 mm	40 mm	50 mm
	Flange	○	○	○	○
Rc3/8	○	×	×	×	×
Rc1/2	○	○	×	×	×
Rc3/4	×	○	○	×	×
Rc1	×	×	○	×	×

Note) ○: Producible ×: Unproducible

DIMENSION

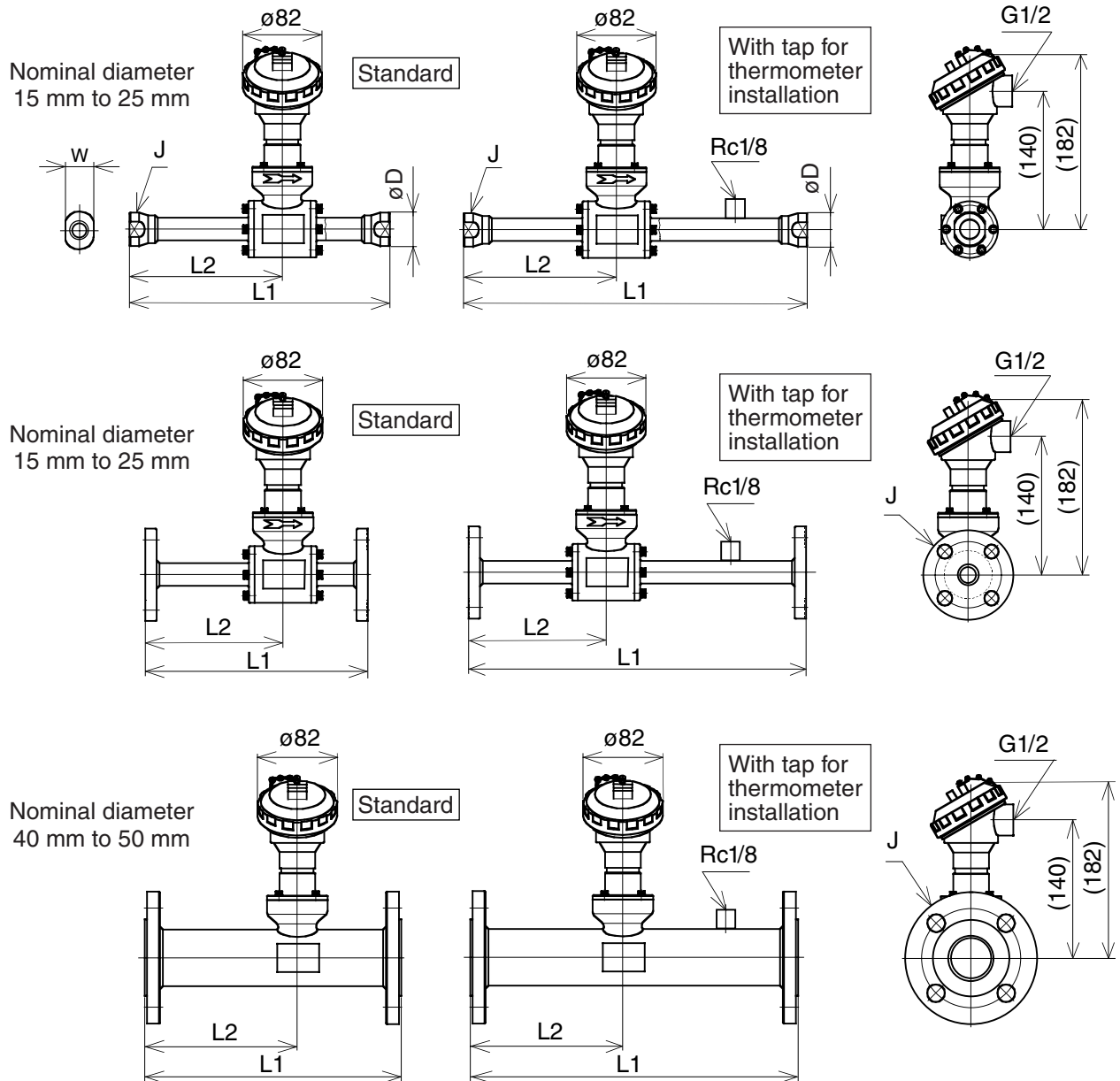

Standard type

Size	L1	L2	J	øD	W
15 mm	210	105	Rc3/8 • Rc1/2	ø36	32
	180	90	15A JIS10K flange	-	-
20 mm	250	145	Rc1/2 • Rc3/4	ø36	32
	220	130	20A JIS10K flange	-	-
25 mm	280	170	Rc3/4 • Rc1	ø46	41
	240	150	25A JIS10K flange	-	-
40 mm	280	170	40A JIS10K flange	-	-
50 mm	320	210	50A JIS10K flange	-	-

With tap for thermometer installation type

Size	L1	L2	J	øD	W
15 mm	300	105	Rc3/8 • Rc1/2	ø36	32
	270	90	15A JIS10K flange	-	-
20 mm	340	145	Rc1/2 • Rc3/4	ø36	32
	310	130	20A JIS10K flange	-	-
25 mm	370	170	Rc3/4 • Rc1	ø46	41
	330	150	25A JIS10K flange	-	-
40 mm	350	170	40A JIS10K flange	-	-
50 mm	390	210	50A JIS10K flange	-	-

SENSOR WITH PURGE FUNCTION

TH-1100-SP / TH-3200-SP

OUTLINE

TH-1100-SP / TH-3200-SP are the sensors with purge function. Purged gas prevents the dust to the sensor section from adhering and removes the adhered dust, resulting in performing the stable measurement of flow rate.

Note: Regarding the adhesive dust, it may be that the sufficient effect can not be obtained.



MODEL CODE

TH—11 TH—32	Model code						Description
	①	②	③	④	⑤	—SP	
① Process pipe size	A						150 mm (6")
	B						200 mm (8")
	C						250 mm (10")
	D						300 mm (12")
	E						350 mm (14")
	F						Others
② Sensor material	1						SUS304
	2						SUS316
	3						SUS316L
	F						Special
③ Process connection	1						65A JIS10K flange
	F						Others
④ L length	1						Standard
	F						Special
⑤ Special							Standard type (Blank)
					C		Connector type (Make it blank if in case of terminal box type.)

STANDARD SPECIFICATION

Model	TH-1100-SP	TH-3200-SP
Type	Insertion type (Std. 65A JIS10K flange)	
Available size	150 mm (6") to 1500 mm (60") * Up to 1500 mm size available on request.	
Measuring range	Min.	Air : 0 to 0.5 m/s (nor) Air : 0 to 5 m/s (nor)
	Max.	Air : 0 to 75 m/s (nor)
Max. Op. Press.	1.0 MPa	0.1 MPa
Max. Op. Temp. segment	80°C / 240°C	550°C
Material	Sensor	SUS316
	Detector	SUS304, SUS316, SUS316L
	Seal	FPM, Others
Water proof	IP65 equiv.	
Required upstream straight run (Recommendation)	20D (D: Inside diameter)	

DIMENSION

TH-1100-SP

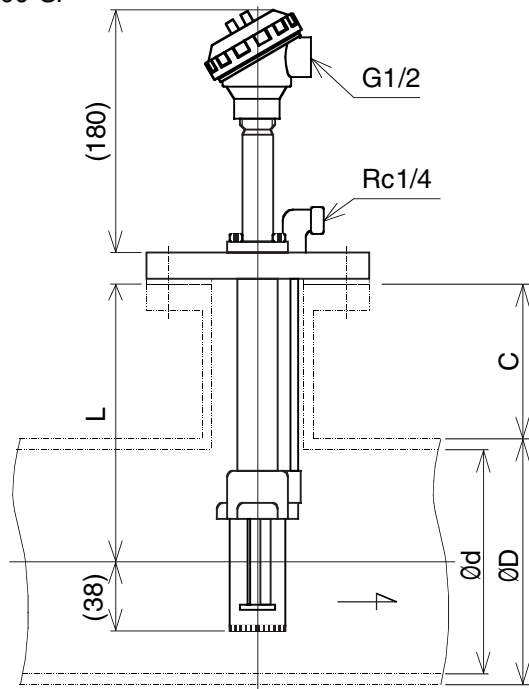

TH-3200-SP

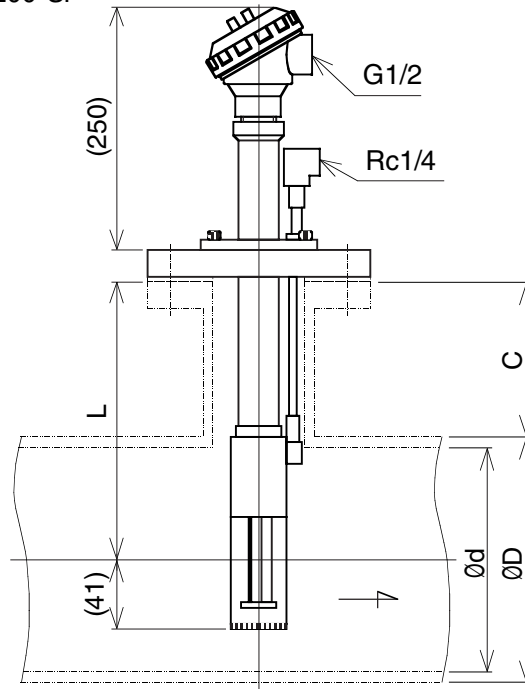

Process pipe size (mm)	L (mm)
150	182
200 to 250	200
300 to 350	250
More than 400	Consult factory for details

Note:

- In case of the dimension except our standard one, advise us of the required dimension for "L" or "C".
- Advise us of the dimension for "Ød" and "ØD".

HIGH AND LOW TEMP. VERSION TH-3100 / TH-3200 / TH-3300

OUTLINE

HIGH AND LOW TEMP. VERSION is available for TH series THERMAL FLOWMETER.

Low temp. version covers upto minus 196°C and High temp. version covers upto plus 550°C.

HIGH AND LOW TEMP. VERSION will be used together with TRX-600 type converter.

MODEL CODE

TH-3	Model code					Description
	①	②	③	④	⑤	
① Type	1					For high temp. Max. 1.0 MPa press.
	2					For high temp. Max. 0.1 MPa press.
	3					For low temp. Max. 0.1 MPa press.
② Process pipe size	6					65 mm (2-1/2") *TH-3200/TH-3300
	7					80 mm (3")
	8					100 mm (4")
	9					125 mm (5")
	A					150 mm (6")
	B					200 mm (8")
	C					250 mm (10")
③ Sensor material	D					300 mm (12")
	E					350 mm (14")
	F					Others
	1					SUS304
	2					SUS316
	3					SUS316L
④ Process connection	F					Special
	1					Standard
⑤ L length	1					Standard
	F					Special

STANDARD SPECIFICATION

Model	TH-3100	TH-3200	TH-3300
Type	Insertion type		
	Std. 65 A JIS10K flange	Std. 32 A JIS10K flange	
Available size	80 mm (3") to 1500 mm (60")	65 mm (2-1/2") to 1500 mm (60")	
Measuring range	Min.	Air : 0 to 5 m/s (nor)	
	Max.	Air : 0 to 75 m/s (nor)	
Max. Op. Press.	1.0 MPa	0.1 MPa	
Max. Op. Temp.	0 to 550°C (for high temp.)		-196 to 0°C (for low temp.)
Material	Sensor	SUS316	
	Detector	SUS304, SUS316, SUS316L	
Water proof	IP65 equiv.		
Required upstream straight run (Recommendation)	20D (D: Inside diameter)		



DIMENSION

- Sensor
- TH-3100
- TH-3200 / TH-3300

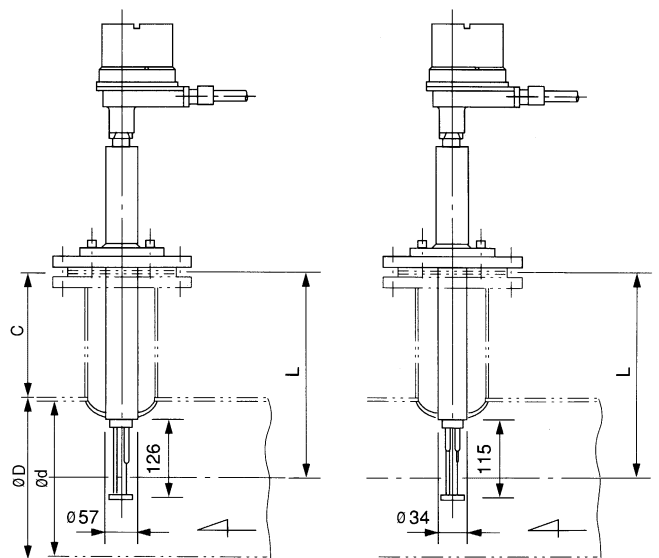

Process pipe size(mm)	L (mm)	Process pipe size(mm)	L (mm)
80 to 150	182	65 to 150	182
200 to 250	200	200 to 250	200
300 to 350	250	300 to 350	250
More than 400	Consult factory for details	More than 400	Consult factory for details

Note:

- In case of the dimension except our standard one, advise us of the required dimension for "L" or "C".
- Advise us of the dimension for "Ød" and "ØD."

TH THERMAL FLOWMETER

HIGH QUALITY SENSORS TH-1100-HQ

OUTLINE

TH-1100-HQ is a insertion type detector. EP polished surface and hermetical sealing have achieved elimination of depositing of particles and low leakage rate.

TH-1100-HQ is suitable for applications with high grade quality control such as gas supply lines in semi-conductor production facilities.



MODEL CODE

Model code			Description
TH-11	①	② —HQ	
① Process pipe size	5		50 mm
	6		65 mm
	7		80 mm
	8		100 mm
② Sensor material	1		Standard
	F		Special

STANDARD SPECIFICATION

Type	High quality version (Insertion type) (Special flange nozzle)	
Available size	50 mm (2") to 100 mm (4")	
Measuring range	Min.	Air : 0 to 0.5 m/s (nor)
	Max.	Air : 0 to 75 m/s (nor)
Max. Op. Press.	1.0 MPa	
Max. Op. Temp.	120°C (180°C as option)	
Material	Body	SUS316L, EP polished Surface roughness Rmax. ≒ 0.7 μm
	Sensor	SUS316, OVAR(Ni,Co alloy) + AL ₂ O ₃ + Gold brazing + Ni plated, BA treatment
	Seal	Body PTFE coated Metal O ring Sensor SUS316
He leak rate	Max. 1×10 ⁻¹⁰ Pa·m ³ /s	
Construction	Water proof (IP65 equiv.)	
Scope of supply	Standard 1) Sensor 2) Special flange piece (for pipe welding) 3) Metal O ring	
	On request Spacer for installation to pipe by welding	

DIMENSION

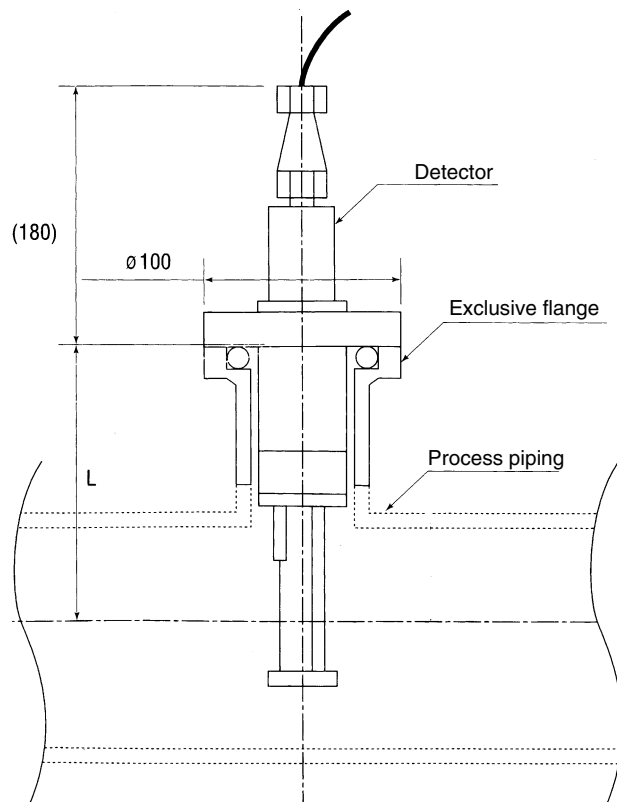

Size (mm)	Dimension (mm)
	L
50 mm	94
65 mm	94
80 mm	120
100 mm	120

TH-1500-HQ

OUTLINE

TH-1500-HQ is a High quality, in-line installatin type detector. Like TH-1500-HQ, EP polished surface and metal sealing have achieved elimination of depositing of particles and low leakage rate and is also suitable for semi-conductor production facilities.

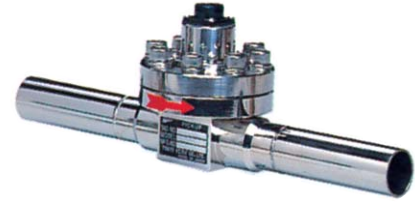

MODEL CODE

Model code				Description
TH-15	①	②	③	
① Process pipe size	1			15 mm
	2			20 mm
	3			25 mm
② Sensor material	1			Standard
	F			Special
③ Process connection	1			Welding type (I fusion face)
	F			Others

STANDARD SPECIFICATION

Type	High quality version (Process piping welding type)	
Available size	15 mm (1/2") to 25 mm (1")	
Measuring range	Min.	Air : 0 to 0.5 m/s (nor)
	Max.	Air : 0 to 75 m/s (nor)
Max. Op. Press.	1.0 MPa	
Max. Op. Temp.	120°C (180°C as option)	
Material	Body	SUS316L, EP polished Surface roughness Rmax. ≤ 0.7 μm
	Sensor	SUS316, OVAR (Ni,Co alloy) + Al ₂ O ₃ + Gold brazing + Ni plated, BA treatment
	Seal	Body PTFE coated Metal O ring Sensor SUS316
He leak rate	Max. 1×10 ⁻¹⁰ Pa·m ³ /s	
Construction	Water proof (IP65 equiv.)	

DIMENSION

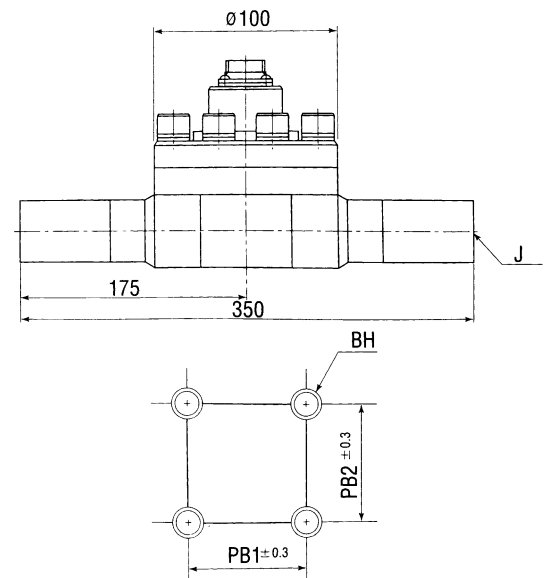

Size (mm)	Dimension (mm)							
	J	L	H1	H2	H3	PB1	PB2	BH
15 mm	ø21.7×1.65t	350	20	95	115	30	40	4-M4 (d - 6)
20 mm	ø27.2×1.65t							
25 mm	ø34.0×1.65t							

TRX-600

OUTLINE

TRX-600 is the converter designed for the thermal flowmeter of the field installation type in waterproof construction. By having improved the loaded CPU performances, the high precision and high efficiency have been achieved, and most operation factors can be set up or modified by the users, just by the key operation on the front panel. Moreover, the maximum 8 kinds of data are programmable beforehand, and also it is possible to expand the various functions by the optional circuit board.

MODEL CODE

MODEL CODE										CONTENTS	
TRX-6											
Temperature correction (Input signal)	0										
	1										Resistance temp. sensor (Pt100Q)
	2										DC4 to 20mA temp. signal
	3										DC1~5V temp. signal
Power supply	1										AC100V±10%
	2										AC110V±10%
	3										AC115V±10%
	4										AC200V±10%
	5										AC220V±10%
	6										AC240V±10%
Cable length	1										5m
	2										10m
	3										15m
	4										20m
	5										25m
	6										30m
	7										40m
	8										50m
Cable entry									1		G1/2
									F		Other
									0		Not provided
2" pipe mount fitting									1		Provided
									0		Not provided
Optional circuit board (*1) If there is no optional function, make it blank.	Purge control output								0		No purge control provided
									1		Open collector (Standard)
									2		Contact input
	Purge output								0		No purge control provided
									1		O.C.+Contact output
									2		O.C.+AC Power output
	Contact output								1		Flow switch
									2		Abnormality alarm output

*1: The optional circuit board will be released in the near future and it does not correspond at present.
O.C.= Open collector

DIMENSION

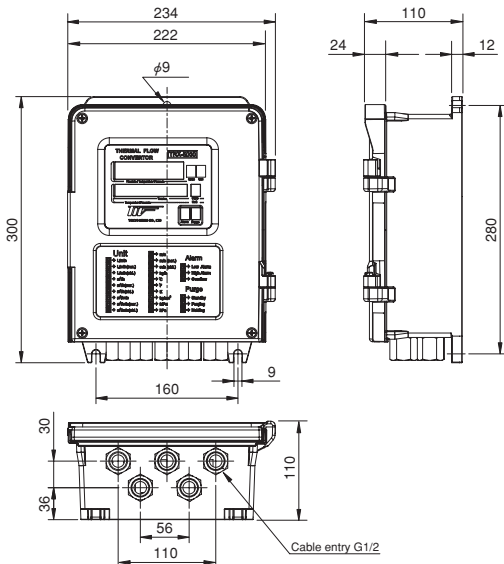

STANDARD SPECIFICATION

Connectable detector	TH-1100(-HQ)/1200/1400/1500-HQ 1700/1800/3000/1100-SP/3200-SP	
Installation	Installation on wall or 2" pipe	
Protective construction	Jet-proof type (IP65 equivalent)	
Accuracy	Indication	±2.0%F.S.±1 digit
	Output	±2.0%F.S.
	Integration	±2.0%F.S.
Display	Upper side	Selected and displayed by Instantaneous flow and temperature Flow rate: 6-digit LED (0.000 to 999999) Temperature: 4-digit LED (-25.0 to 550.0) (*1)
		Lower side
	Lower right	Displayed on the panel [ALARM] [H] Upper, [L] Lower & [E] Abnormal
Analog output	DC4 to 20mA, and allowable load resistance: Less than 500Ω	
Pulse output	Open collector output PhotoMOS relay, DC30V/100mA (Max)	
Digital output RS-485	2400/4800/9600bps (Selectable) ID Address: 0 to 99 Protocol: 8N1 Output: Instantaneous flow, integrated flow, temperature, and error code	
Temperature correction function	3-wire type resistance temp. sensor (Pt100) or temp. sensor with analog output (DC4 to 20mA or DC1 to 5V) is separately required.	
Alarm output (*2)	1 point out of [H], [L], & [E] SPDT Relay contact output AC240V/0.4A (DC30V/2A) AC240V/0.4A (DC30V/2A)	
Purge control function (*2)	Valve control output function for purge operation Purge cycle and time settable Output: AC (Input power supply) or contact	
Response speed	3 to 5 sec. (63% Step response)	
Electric connection	Pin terminal connector	
Power supply	AC100, 110, 115, 200, 220, 240V ±10% 50/60Hz	
Power consumption	Approx.30VA	
Housing	Aluminum die-cast / Cobalt blue or Silver	
Dimension	234W × 300H × 110D (mm)	
Mass	5.4 kg (Wall mount) 7.4kg (2" pipe)	
Ambient temperature	-10 to 60°C	
Ambient humidity	10 to 90%RH (No dew condensation)	

*1: The thermometer is separately required for the temperature display.
*2: When using the alarm output and purge control function, the optional circuit board is additionally required.

TRX-700 / TRX-900

OUTLINE

TRX-700 / TRX-900 series are an intelligent type converter for thermal flowmeters. High-precision and high-performance capacities have been achieved by the new design of a signal processing circuit mounting double CPU's.

All the operation factors are handled by the operating keys arranged on the front panel that enables to make settings and alterations in a user-friendly way.

Functions necessary for process monitoring and controlling such as flow rate, totalization and alarm output are all installed as the standard specification.

In addition, data processing with a host computer has made available through serial communication with RS-485 interface.

Easy maintenance with self-diagnosis function

DIN96 × 96 compact housing

Two types available

- a) TRX-700 Panel mount type
- b) TRX-900 Field mount type (Water proof housing)

MODEL CODE

Model code			Description
TRX-	①	② ③	
① Type	7		DIN 96 × 96 Panel mount type
	9		Water proof housing, Field mount type
② Temperature and pressure correction	0		No correction
	1		Temperature correction
	4		Temp. and Press. correction
③ Cable length	1		5 m
	2		10 m
	3		15 m
	4		20 m
	5		25 m
	6		30 m
	7		35 m
	8		40 m
	9		45 m
	A		50 m
F		50 m to 100 m *Specify the cable length	

STANDARD SPECIFICATION

Connectable detector	TH-1100/1100-HQ/1200 1400/1500-HQ/1700/1800	
Installation	TRX-700 : Panel mount type (DIN 96 × 96) TRX-900 : Wall or 2B pipe mount type)	
Construction	TRX-700 : IP20 equiv. (Indoor use) TRX-900 : IP54 equiv. (Field use)	
Accuracy	Analog output	±1%F.S. ± 1digit (Flow rate)
	Pulse output	±1.05%F.S. ± 1digit (Totalization)
Analog output	DC 4 to 20 mA / Allowable load resistance 500Ω	
Pulse output	Open collector output / DC 35 V / 50 mA (max.) Pulse width : 50, 100, 200 msec Pulse rate : 0.0 to 600 c/min 0 to 36000 c/h	
Contact output of alarm	SPDT relay contact (High alarm/ Low alarm) AC 125 V/0.4 A (DC 20 V/2 A)	
Digital output (RS-485)	1200 / 2400 / 4800 / 9600bps (Selectable) ID address : 00 to 99 Protocol : 8N1 Output : Flow rate, totalization, bar graph, temp., pressure, heating current, firmware version, serial No., error message, etc.	
Display	Dot matrix LCD, 16 characters × 2 lines With backlight	
Indication	Upper section	Select one item from flow rate, totalization, temp., Pressure, heating voltage, internal temp. and SPS ripple, or error message.
	Lower section	Select one item from bar graph, flow rate, Totalization, temp., pressure and heating current, Or error message.
Maximum number of display digits	Analog output	5 digits (0.000 to 99999) (Flow rate)
	Pulse output	7 digits (0.00 to 9999999) (Totalization)
Temp. correction function	3-wire type resistance temp. sensor (Pt100 Ω) is required separately.	
Pressure correction function	Pressure gauge with DC 4 to 20 mA analog output is required separately. (Used mainly for indication of actual flow rate.)	
Response time	3 seconds (63% step response)	
Dimensions	96 H × 96 W × 243 D (mm)	
Mass	About 1.95 kg	
Cable length	100 m (max.)	
Power supply	AC 90 to 264 V 50/60 Hz	
Power consumption	60 W (max.)	
Elect. connection	Pin terminal connector	
Ambient temp.	0 to 50°C	
Ambient humidity	10 to 90% RH (No dew condensation)	



TRX-700



TRX-900

DIMENSION

- TRX-700 (Panel mount type)

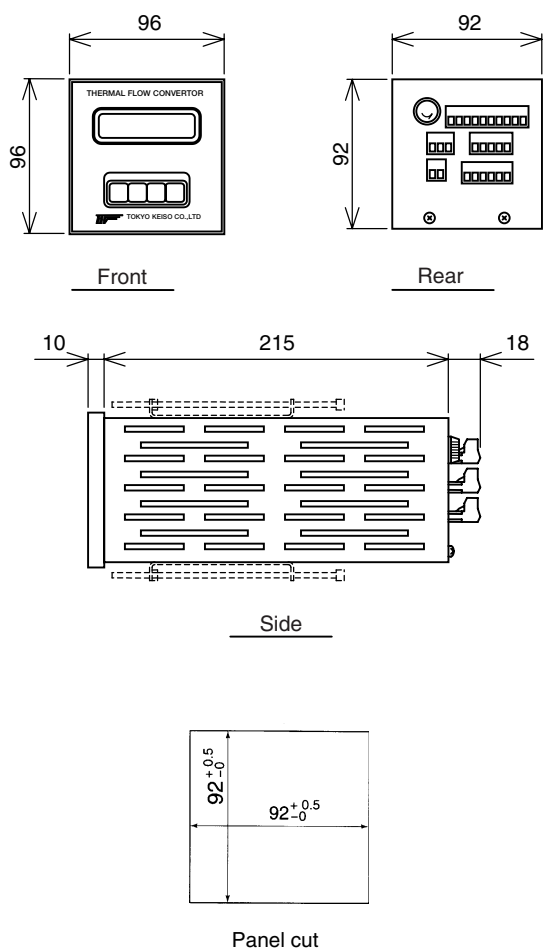

- TRX-900 (Wall mount type)

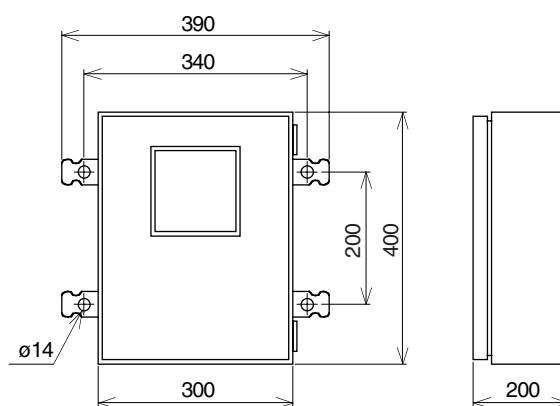

- TRX-900 (2B pipe mount type)

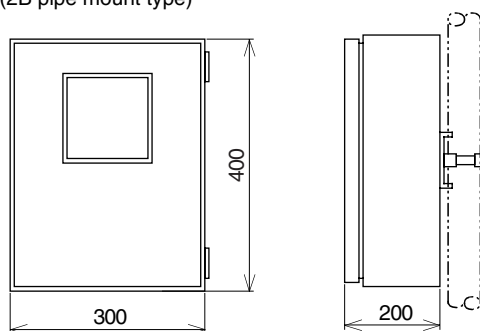

FLOW RATE RANGE (Full scale)

TH-1100/TH-1400

Unit : m³/h(nor)

Gas Size	AIR	N ₂	CO ₂	O ₂	Ar	13A	CH ₄	C ₃ H ₈	C ₄ H ₁₀	NH ₃	He	H ₂
50 mm	45 to 840	45 to 840	25 to 1135	45 to 820	40 to 1675	40 to 545	50 to 550	15 to 540	10 to 440	40 to 800	5 to 34	5 to 30
65 mm	60 to 1395	60 to 1395	30 to 1885	60 to 1360	50 to 2775	50 to 905	65 to 915	20 to 895	10 to 735	55 to 1330	7 to 45	7 to 39
80 mm	70 to 1965	70 to 1965	35 to 2655	70 to 1915	60 to 3915	60 to 1275	75 to 1290	20 to 1260	15 to 1035	65 to 1875	10 to 53	10 to 47
100 mm	90 to 3385	90 to 3380	50 to 4570	90 to 3295	80 to 6735	80 to 2195	100 to 2220	25 to 2170	20 to 1785	85 to 3225	17 to 69	17 to 62
125 mm	115 to 5155	115 to 5145	60 to 6955	115 to 5020	100 to 10250	100 to 3340	120 to 3380	35 to 3305	20 to 2715	105 to 4910	26 to 85	26 to 78
150 mm	135 to 7360	135 to 7345	70 to 9940	135 to 7170	120 to 14640	120 to 4775	145 to 4830	40 to 4720	25 to 3880	125 to 7010	37 to 98	37 to 89
200 mm	175 to 12650	175 to 12625	90 to 17080	175 to 12325	155 to 25160	155 to 8205	190 to 8300	50 to 8115	35 to 6670	160 to 12050	1200 to 1584	65 to 109
250 mm	220 to 19685	220 to 19650	115 to 26580	220 to 19180	190 to 39160	190 to 12770	235 to 12920	60 to 12630	40 to 10380	200 to 18750	1460 to 2457	1330 to 1537
300 mm	260 to 28145	260 to 28090	150 to 37995	260 to 27415	230 to 55980	230 to 18255	280 to 18465	75 to 18060	60 to 14835	240 to 26810	1780 to 3498	1620 to 2189
350 mm	295 to 35190	295 to 35125	185 to 47510	295 to 34280	270 to 69995	255 to 22825	315 to 23090	90 to 22580	75 to 18550	265 to 33520	2170 to 4058	1930 to 2539
400 mm	335 to 46460	335 to 46375	245 to 62725	335 to 45260	355 to 92405	295 to 30130	360 to 30485	115 to 29810	95 to 24490	305 to 44255		
450 mm	380 to 59310	380 to 59200	310 to 80070	380 to 57775	455 to 117960	335 to 38465	410 to 38915	150 to 38055	120 to 31265	345 to 56490		
500 mm	425 to 73440	425 to 73305	385 to 99150	425 to 71540	565 to 146065	370 to 47630	455 to 48190	185 to 47125	150 to 38715	385 to 69950		
550 mm	470 to 89420	470 to 89255	465 to 120725	470 to 87110	685 to 177850	410 to 57995	505 to 58675	225 to 57380	185 to 47140	425 to 85175		
600 mm	510 to 106260	510 to 106060	555 to 143460	510 to 103510	815 to 211345	445 to 68920	550 to 69725	265 to 68185	215 to 56020	465 to 101215		
650 mm	555 to 124170	555 to 123940	645 to 167635	555 to 120960	950 to 246965	485 to 80535	595 to 81475	310 to 79675	255 to 65460	500 to 118275		
700 mm	595 to 144735	595 to 144465	755 to 195405	595 to 140995	1110 to 287870	525 to 93875	640 to 94970	360 to 92875	295 to 76300	540 to 137865		
750 mm	645 to 166885	645 to 166575	870 to 225305	645 to 162570	1280 to 331920	560 to 108240	690 to 109505	415 to 107090	340 to 87980	615 to 158960		
800 mm	735 to 190610	735 to 190260	990 to 257340	715 to 185685	1460 to 379115	600 to 123630	735 to 125075	470 to 122315	390 to 100490	700 to 181560		
850 mm	830 to 215920	830 to 215520	1125 to 291510	810 to 210340	1655 to 429455	640 to 140045	785 to 141685	535 to 138555	440 to 113830	795 to 205670		
900 mm	935 to 242815	935 to 242365	1265 to 327815	910 to 236535	1860 to 482940	680 to 157485	830 to 159330	600 to 155810	495 to 128005	890 to 231285		
1000 mm	1155 to 299520	1155 to 298965	1555 to 404370	1125 to 291775	2295 to 595725	755 to 194265	925 to 196540	740 to 192200	610 to 157900	1100 to 285300		
1100 mm	1405 to 365118	1405 to 364440	1900 to 492930	1370 to 355675	2795 to 726190	915 to 236810	1020 to 239580	905 to 234295	740 to 192485	1340 to 347780		
1200 mm	1675 to 435020	1675 to 434215	2260 to 587310	1630 to 423775	3330 to 865225	1085 to 282150	1115 to 285450	1075 to 279150	885 to 229335	1600 to 414365		
1300 mm	1965 to 511050	1965 to 510105	2655 to 689955	1915 to 497840	3910 to 1016445	1275 to 331465	1290 to 335340	1265 to 327940	1040 to 269420	1875 to 486785		
1400 mm	2280 to 593200	2280 to 592105	3080 to 800870	2225 to 577870	4540 to 1179850	1480 to 384750	1500 to 389250	1460 to 380660	1205 to 312730	2175 to 565045		
1500 mm	2620 to 681490	2620 to 680225	3540 to 920060	2555 to 663870	5215 to 1355435	1700 to 442010	1720 to 447175	1685 to 437310	1385 to 359270	2500 to 649135		

TH-1200 [Without flow Straightener]

Unit : m³/h(nor)

Gas Size	AIR	N ₂	CO ₂	O ₂	Ar	13A	CH ₄	C ₃ H ₈	C ₄ H ₁₀	NH ₃	He	H ₂
50 mm	45 to 840	45 to 840	25 to 1135	45 to 820	40 to 1675	40 to 545	50 to 550	15 to 540	10 to 440	40 to 800	5 to 34	5 to 30
65 mm	60 to 1395	60 to 1395	30 to 1885	60 to 1360	50 to 2775	50 to 905	65 to 915	20 to 895	10 to 735	55 to 1330	7 to 45	7 to 39
80 mm	70 to 1965	70 to 1965	35 to 2655	70 to 1915	60 to 3915	60 to 1275	75 to 1290	20 to 1260	15 to 1035	65 to 1875	10 to 53	10 to 47
100 mm	90 to 3385	90 to 3380	50 to 4570	90 to 3295	80 to 6735	80 to 2195	100 to 2220	25 to 2170	20 to 1785	85 to 3225	17 to 69	17 to 62
125 mm	115 to 5155	115 to 5145	60 to 6955	115 to 5020	100 to 10250	100 to 3340	120 to 3380	35 to 3305	20 to 2715	105 to 4910	26 to 85	26 to 78
150 mm	135 to 7360	135 to 7345	70 to 9940	135 to 7170	120 to 14640	120 to 4775	145 to 4830	40 to 4720	25 to 3880	125 to 7010	37 to 98	37 to 89

TH-1200 [With flow Straightener]

Unit : m³/h(nor)

Gas Size	AIR	N ₂	CO ₂	O ₂	Ar	13A	CH ₄	C ₃ H ₈	C ₄ H ₁₀	NH ₃	He	H ₂
50 mm	5 to 285	5 to 285	5 to 385	5 to 275	0 to 565	5 to 185	5 to 185	5 to 180	5 to 150	5 to 270	5 to 99	5 to 61
65 mm	10 to 450	10 to 450	10 to 610	10 to 440	15 to 895	5 to 290	5 to 295	5 to 290	5 to 235	5 to 430	7 to 180	7 to 108
80 mm	10 to 690	10 to 690	15 to 930	10 to 670	20 to 1375	10 to 445	10 to 450	10 to 440	5 to 365	10 to 655	10 to 254	10 to 159
100 mm	15 to 1200	15 to 1200	20 to 1625	15 to 1170	30 to 2390	10 to 780	10 to 790	10 to 770	10 to 635	15 to 1145	17 to 428	17 to 267
125 mm	25 to 1810	25 to 1810	35 to 2445	25 to 1760	45 to 3600	15 to 1175	15 to 1185	15 to 1160	15 to 955	25 to 1725	26 to 645	26 to 403
150 mm	35 to 2605	35 to 2605	45 to 3520	35 to 2540	65 to 5185	25 to 1690	25 to 1710	25 to 1670	20 to 1375	35 to 2480	37 to 916	37 to 573

TH-1700

Unit : L/min(nor)

Gas Size	AIR	N ₂	CO ₂	O ₂	Ar	13A	CH ₄	C ₃ H ₈	C ₄ H ₁₀	NH ₃	He	H ₂
15 mm	235 to 1355	235 to 1355	120 to 1830	235 to 1320	205 to 2700	205 to 880	250 to 890	65 to 870	45 to 715	215 to 1290	8 to 160	8 to 100
20 mm	315 to 2430	315 to 2430	165 to 3285	315 to 2370	275 to 4840	275 to 1575	340 to 1595	90 to 1560	60 to 1280	285 to 2315	15 to 280	15 to 170
25 mm	400 to 3900	400 to 3895	210 to 5270	400 to 3800	350 to 7760	350 to 2530	430 to 2560	115 to 2505	75 to 2055	365 to 3715	20 to 350	20 to 260
40 mm	620 to 9295	620 to 9280	320 to 12550	620 to 9055	545 to 18490	545 to 6030	665 to 6100	175 to 5965	115 to 4900	565 to 8855	50 to 530	50 to 480
50 mm	775 to 14815	775 to 14790	400 to 20005	775 to 14435	680 to 29470	675 to 9610	830 to 9720	215 to 9505	145 to 7810	705 to 14115	70 to 670	70 to 600

TH-1800

Unit : L/min(nor)

Gas Size	AIR	N ₂	CO ₂	O ₂	Ar	13A	CH ₄	C ₃ H ₈	C ₄ H ₁₀	NH ₃	He	H ₂
15 mm	10 to 560	10 to 560	10 to 760	10 to 550	15 to 1120	5 to 365	5 to 370	5 to 360	5 to 295	10 to 535	2 to 130	1 to 80
20 mm	15 to 1010	15 to 1010	15 to 1365	15 to 985	25 to 2010	10 to 655	10 to 660	10 to 645	10 to 530	15 to 960	3 to 240	2 to 150
25 mm	20 to 1620	20 to 1620	25 to 2185	20 to 1580	40 to 3225	15 to 1050	15 to 1060	15 to 1040	10 to 855	20 to 1545	5 to 400	3 to 240
40 mm	40 to 3540	40 to 3535	55 to 4780	40 to 3450	80 to 7045	30 to 2295	30 to 2325	25 to 2270	25 to 1865	40 to 3370	10 to 940	6 to 570
50 mm	65 to 5855	65 to 5845	90 to 7905	65 to 5705	130 to 11645	45 to 3795	45 to 3840	45 to 3755	35 to 3085	65 to 5575	16 to 1520	10 to 920

TH-3200-SP

Unit : m³/h(nor)

Gas Size	AIR	N ₂	CO ₂	O ₂	Ar	13A	CH ₄	C ₃ H ₈	C ₄ H ₁₀	NH ₃
150 mm	255 to 3815	255 to 3805	345 to 5150	250 to 3715	510 to 7585	165 to 2475	170 to 2500	165 to 2445	135 to 2010	245 to 3635
200 mm	455 to 6805	455 to 6790	615 to 9185	445 to 6625	905 to 13530	295 to 4410	300 to 4465	295 to 4365	240 to 3585	435 to 6480
250 mm	725 to 10830	725 to 10810	975 to 14625	705 to 10550	1440 to 21545	470 to 7025	475 to 7105	465 to 6950	385 to 5710	690 to 10315
300 mm	1045 to 15675	1045 to 15645	1415 to 21165	1020 to 15270	2080 to 31180	680 to 10165	690 to 10285	675 to 10060	555 to 8265	1000 to 14930
350 mm	1315 to 19715	1315 to 19680	1775 to 26620	1285 to 19205	2615 to 39215	855 to 12785	865 to 12935	845 to 12650	695 to 10395	1255 to 18780
400 mm	1750 to 26185	1745 to 26135	2360 to 35350	1705 to 25505	3475 to 52080	1135 to 16980	1145 to 17180	1120 to 16800	920 to 13805	1665 to 24940
450 mm	2240 to 33560	2235 to 33500	3025 to 45310	2180 to 32695	4450 to 66755	1455 to 21770	1470 to 22020	1440 to 21535	1180 to 17695	2135 to 31970
500 mm	2780 to 41680	2775 to 41605	3755 to 56275	2710 to 40605	5530 to 82905	1805 to 27035	1825 to 27350	1785 to 26745	1465 to 21975	2650 to 39700
550 mm	3395 to 50865	3385 to 50770	4580 to 68675	3305 to 49550	6745 to 101170	2200 to 32990	2225 to 33375	2180 to 32640	1790 to 26815	3230 to 48450
600 mm	4040 to 60550	4030 to 60435	5450 to 81745	3935 to 58985	8030 to 120430	2620 to 39270	2650 to 39730	2590 to 38855	2130 to 31920	3845 to 57675
650 mm	4725 to 70850	4715 to 70715	6480 to 95650	4605 to 69015	9395 to 140915	3065 to 45950	3100 to 46490	3035 to 45460	2490 to 37350	4500 to 67485
700 mm	5515 to 82680	5505 to 82525	7445 to 111625	5370 to 80540	10965 to 164445	3575 to 53625	3620 to 54250	3540 to 53055	2910 to 43585	5250 to 78755
750 mm	6365 to 95425	6350 to 95245	8590 to 128830	6200 to 92955	12655 to 189790	4130 to 61890	4175 to 62615	4085 to 61230	3355 to 50305	6060 to 90890
800 mm	7275 to 109080	7260 to 108875	9820 to 147265	7085 to 106260	14465 to 216950	4720 to 70745	4775 to 71575	4670 to 69995	3835 to 57505	6930 to 103900
850 mm	8245 to 123645	8230 to 123415	11130 to 166930	8030 to 120450	16395 to 245925	5350 to 80195	5410 to 81135	5290 to 79345	4350 to 65185	7855 to 117775
900 mm	9275 to 139125	9260 to 138870	12525 to 187830	9035 to 135530	18450 to 276715	6020 to 90235	6090 to 91290	5955 to 89275	4890 to 73345	8835 to 132520
1000 mm	11455 to 171775	11435 to 171455	15465 to 231910	11160 to 167335	22780 to 341650	7430 to 111410	7515 to 112715	7350 to 110225	6040 to 90555	10910 to 163620
1100 mm	13970 to 209550	13945 to 209160	18865 to 282905	13610 to 204130	27785 to 416780	9065 to 135910	9170 to 137500	8965 to 134465	7365 to 110470	13310 to 199600
1200 mm	16655 to 249810	16625 to 249350	22485 to 337265	16225 to 243355	33125 to 496860	10805 to 162025	10930 to 163920	10690 to 160300	8780 to 131695	15865 to 237950
1300 mm	19575 to 293605	19540 to 293065	26430 to 396390	19070 to 286015	38935 to 583965	12700 to 190430	12845 to 192655	12565 to 188405	10320 to 154785	18645 to 279665
1400 mm	22730 to 340940	22690 to 340305	30690 to 460290	22145 to 332125	45210 to 678100	14745 to 221130	14915 to 223715	14585 to 218780	11985 to 179735	21650 to 324750
1500 mm	26120 to 391800	26075 to 391075	35265 to 528960	25445 to 381675	51955 to 779270	16945 to 254120	17140 to 257090	16765 to 251415	13770 to 206555	24880 to 373200

*Measuring range : 0 to Full scale

Ex) TH-1100 50 mm, Air

Min. measuring range : 0 to 45 m³/h (nor)

Max. measuring range : 0 to 840 m³/h (nor)

APPLICATION EXAMPLE

Thermal Flowmeter is connected with the special signal cable between sensor and converter. Refer to the following table for details.

- Connection and special signal cable

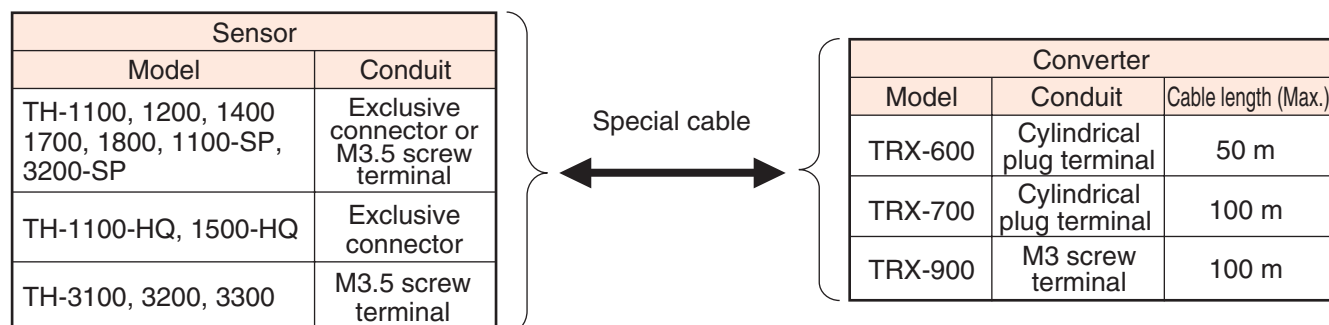

SUGGESTIONS

- TH series Thermal Flowmeter is not suitable for the measurement of gases containing condensate and/or sticking contamination. In that case, we can provide air purge system as option. Consult factory for details.
- Specified straight run for upstream and downstream is required for accurate measurement. Refer to instruction manual for details.

* Specification is subject to change without notice.

TOKYO KEISO CO., LTD.

Head Office : Shiba Toho Building, 1-7-24 Shibakoen, Minato-ku, Tokyo 105-8558

Tel : +81-3-3431-1625 (KEY) ; Fax : +81-3-3433-4922

e-mail : overseas.sales@tokyokeiso.co.jp ; URL : http://www.tokyokeiso.co.jp

